

# Apron plate replacement

## A solution for better dry weight profiles

The apron is one of the most delicate parts of a paper machine, and it has a remarkable effect on the cross-direction profile. The alignment and flatness of this part is critical for the papermaking process.

### Benefits

- Reduces need for slice control
- Reduces CD basis weight variation
- Improves machine runnability
- Improves dry weight profile
- Improves jet flow stability

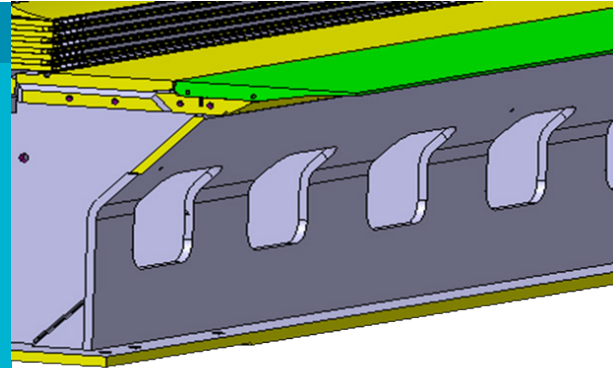

### Service description

Optimal process profiles and end-product quality require that the headbox is in good mechanical condition. Changing the apron requires specialist knowledge and experienced technical skills. We therefore recommend that Valmet conduct the work.

Recommended service interval	When needed
Duration of full service	12–48 hours
Performed during shutdown	12–48 hours
Performed during operation	–

### Scope of service

The service can include:

- Old apron flow angle measurement
- Slice opening profile measurement
- Removing the old apron
- Cleaning the apron contact surface
- Checking the straightness of the apron contact surface
- Installing the new apron
- New apron flow angle measurement and adjustment if required
- Slice opening profile adjustment